



**ALL
MADE
BY ESTUN**

ESTUN AUTOMATION CO.,LTD.

- 📍 No.1888, Jiyin Road, Jiangning Development Zone, Nanjing 211106, P.R.China
- 📍 No.16, Shuige Road, Jiangning Development Zone, Nanjing 211106, P.R.China
- 📍 No.178, Yanhu Road, Jiangning Development Zone, Nanjing 211106, P.R.China
- 📍 No.155, Jiangjun Road, Jiangning Development Zone, Nanjing 211106, P.R.China

- ☎ +86-25-52785866
- 📠 +86-25-52785966
- 🏠 www.estun.com

Service Hotline +86 400 025 3336



Wechat



Website

ProNet Summa Series
Full Digital Servo System



ALL DIGITAL AC SERVO SYSTEMS

ESTUN Automation Co. Ltd. started its business in offering an automation control system for Metal Forming Machinery in 1993 at Nanjing, China. Now ESTUN Automation becomes a leading global product, system and service provider of key industrial automation components/systems, industrial robots and advanced intelligent manufacturing systems.

The Automation Business Group of ESTUN Automation offers a comprehensive product portfolio of servo and motion control products/systems/solutions for General Motion Control and Metal Forming applications. Servo drives, servo motors and EtherCAT based servo systems have been widely used for various Machine Automation applications and served for its global and domestic customers for more than 17 years.

As a global company, ESTUN Automation has 7 oversea branches and serves customers in more than 60 countries and regions. ESTUN Automation will be relentlessly pursuing the excellence in Advanced Motion control solutions, Industrial Robotics (as well as service Robots for rehabilitation, etc.) and Intelligent Manufacturing Systems through collaborating with global subsidiaries and partners, such as Trio Motion Technology; ESTUN Industrial Technology, Europe; M.A.I. GmbH & Co. KG; Euclid Lab; Barrett Technology, etc. in better serving its global customers.

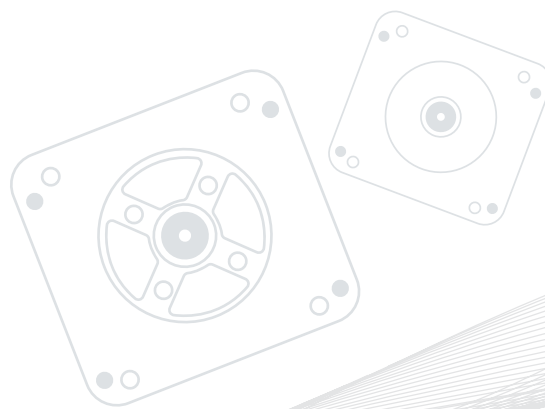
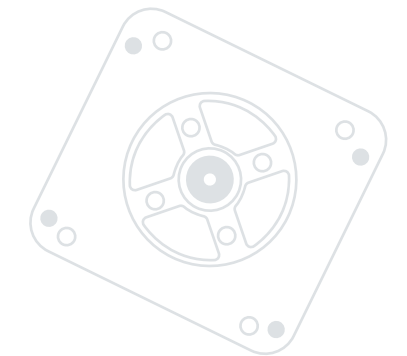

Introduction 03

Part Numbers 08

ProNet Summa Servo Drives 09

Servo Motors 11

Wiring 15

Accessories 16

CONTENTS



01

INTRODUCTION



Drives and Matched Motors

Motors for ProNet Summa Drives

- Absolute or incremental encoder EM3A series motors
- Absolute or incremental encoder EMG series motors

Models	ED3S-02A ED3S-04A	ED3S-08A ED3S-10A ED3S-15A	ED3S-20A ED3S-30A
Drives			
Power / kW	0.2 - 0.4	0.75 - 1.5	2 - 3
Dimension (H×W×D / mm)	172×38×180	172×65×180	172×95×180
Motors			
	EM3A		EMG

Advantages

Zero Stacking

1mm drive installation clearance



High Response

62.5μs current loop cycle, and minimum 125μs EtherCAT update cycle

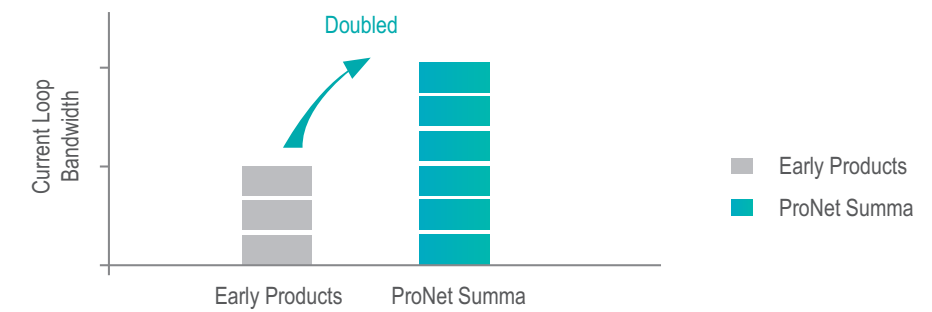

Over-load Capability

Higher acceleration and deceleration with 3.5 times over-load capability

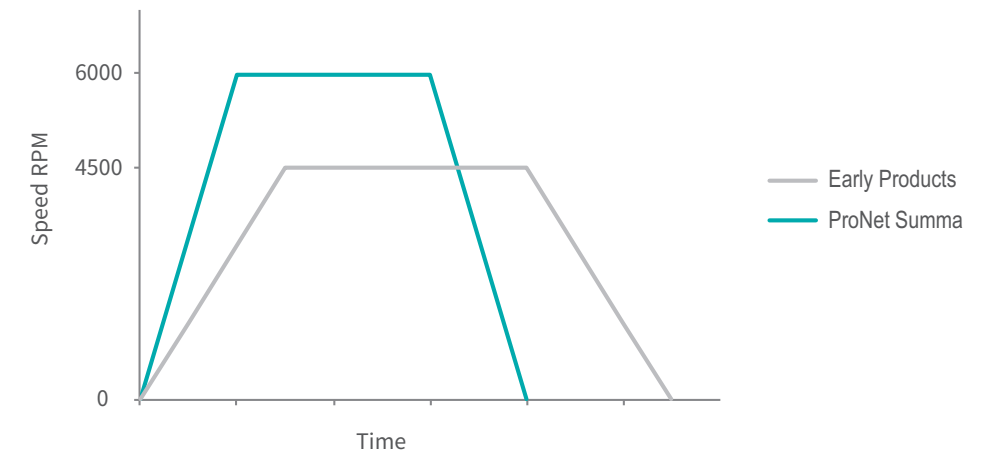

Smart Tuning → Support multiple tuning models

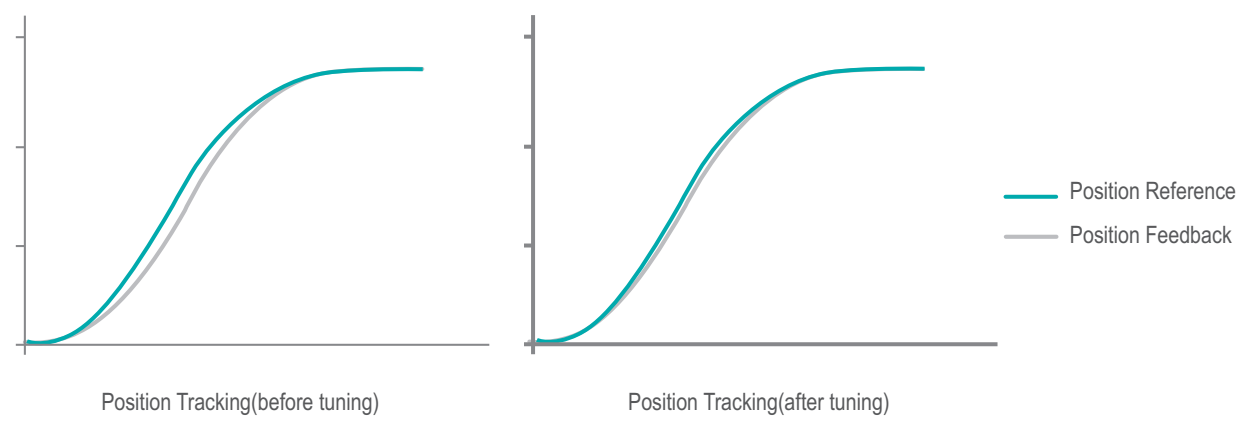

Vibration Suppression → Full-range frequency (1-5kHz) vibration suppression

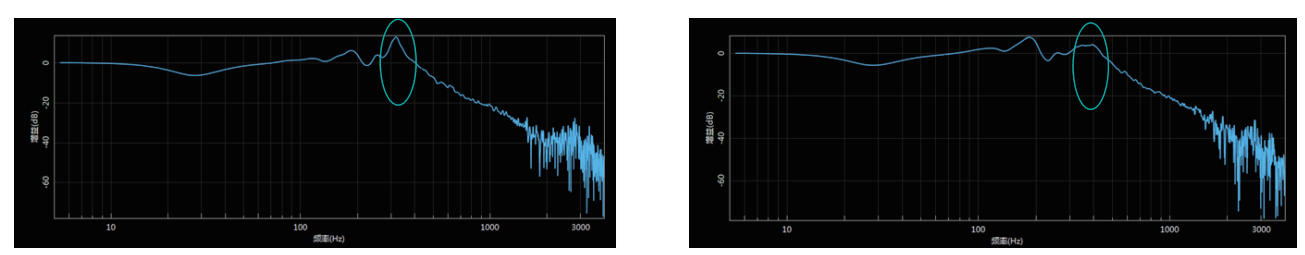

Bode plot mechanical magnitude(before vibration suppression) Bode plot mechanical magnitude(after vibration suppression)

DC-bus Sharing → Multiple power bus sharing approached to save energy & cost

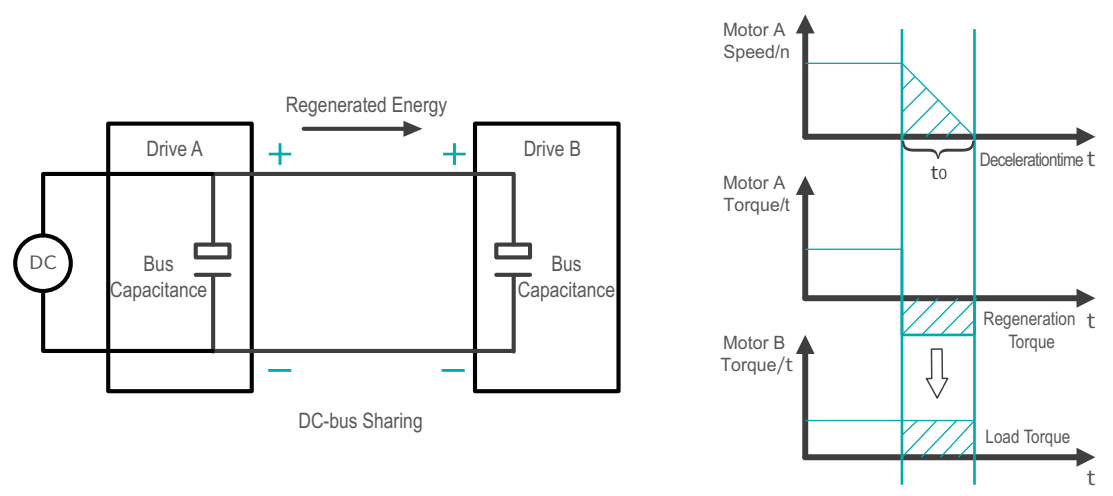

Comprehensive Protection → Improved system reliability

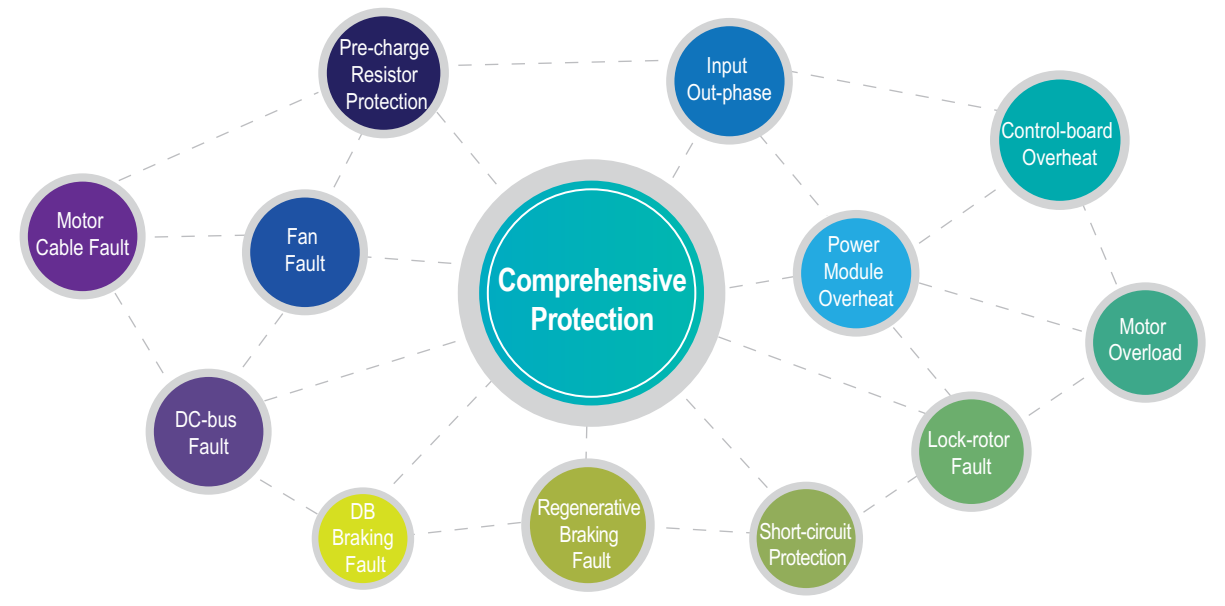

Firmware Upgrade → Upgrading firmware through USB or U-disk

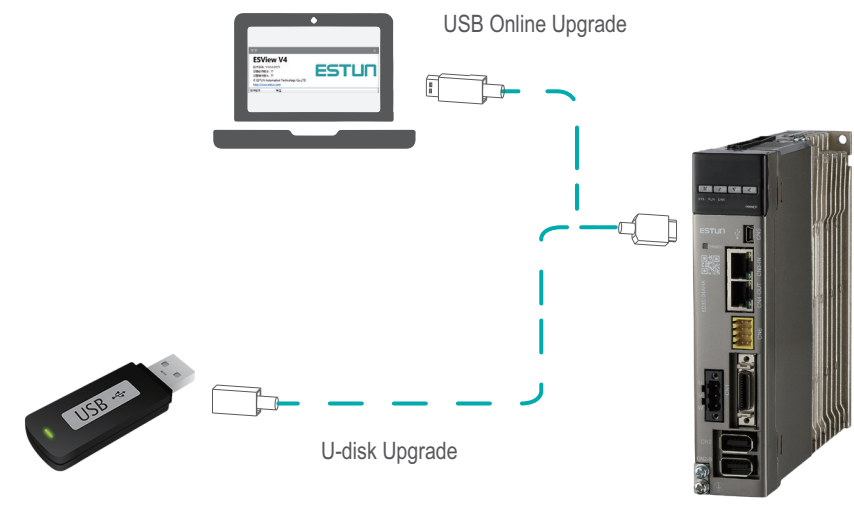

02 PART NUMBERS

Servo Motors	Voltage	Power	Models ①	Encoder Cables ②	Power Cables
ED3S-02AEA ED3S-02AHA	Single-phase/ Three-phase 200VAC	0.2	EM3A-02AFA□□ EM3A-02ALA□□	EC3S-I1124-XX	EC3P-B1118-XX (with brake) EC3P-N1118-XX (without brake)
ED3S-04AEA ED3S-04AHA		0.4	EM3A-04AFA□□ EM3A-04ALA□□		
ED3S-08AEA ED3S-08AHA		0.75	EM3A-08AFA□□ EM3A-08ALA□□		
ED3S-10AEA ED3S-10AHA		1	EM3A-10AFA□□ EM3A-10ALA□□	EC3S-I1324-XX	EC3P-B1314-XX (with brake) EC3P-N1314-XX (without brake)
ED3S-15AEA ED3S-15AHA		1.5	EMG-15AFD□□ EMG-15ALB□□		
ED3S-20AEA ED3S-20AHA	Three-phase 200VAC	2	EMG-20AFD□□ EMG-20ALB□□	EC3S-I1324-XX	EC3P-B2314-XX (with brake) EC3P-N2314-XX (without brake)
ED3S-30AEA ED3S-30AHA		3	EMG-30AFD□□ EMG-30ALA□□		

Appendix Name	Order Type
Battery box (with assembling guideway)	ED3S-BAT-2600-01
Battery box (without assembling guideway)	ED3S-BAT-2600-02
EtherCAT communication cable	DK-HSB-RJ45-XX
USB adjustment cable	USB communication cable MINI-USB double magnetic ring shield -1M5
OTG update cable	USB communication cable OTG-USB-0M15

Note:
 ① □ □ □: shaft ends, brake, oil seal and waterproof options.
 ② XX: Cable length (1M5, 03, 05, 08, 10, 12, 15, 20), the unit is meter. Providing flexible cables, marked with suffix "-RX".
 ③ EC3S-I cable is for incremental encoder. For the absolute encoder, only need to purchase an additional battery box, and one assembling guideway for the first assembling.
 ④ Motor "EMG-30" doesn't have brake cable, providing brake cable socket for clients to make brake cable by themselves.

Function Safety: STO (Safe Torque off, H Version)

Built-in STO function: SIL3, PLLe, Cat.4

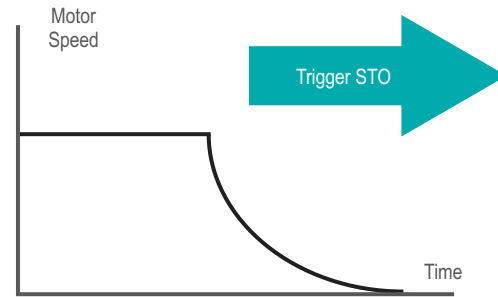
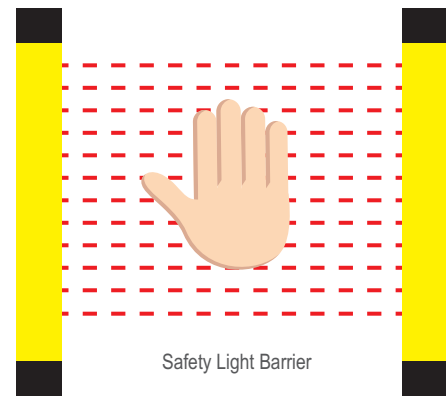

Fully-closed Loop Control (H Version)

Improved system positioning accuracy with secondary encoder at load side

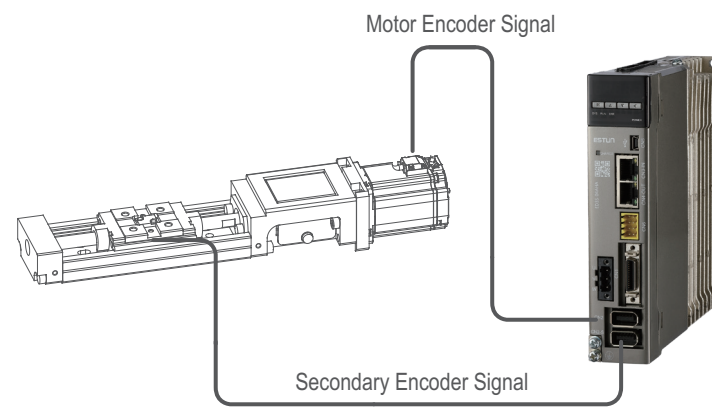

Configuration Tools - ESView

Oscilloscope

Parameter Comparison

Friction Analysis

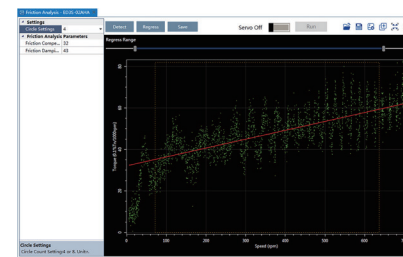
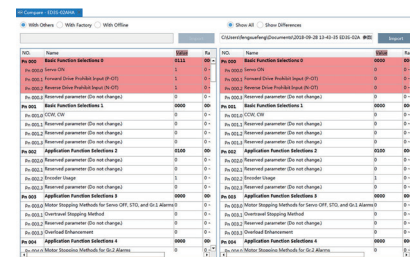
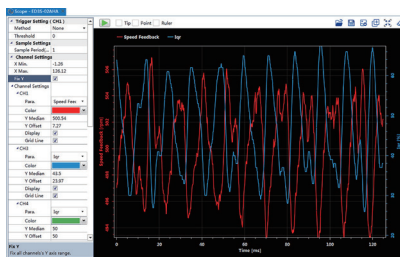

03

PRONET SUMMA SERVO DRIVES



Part Number

ED3S - 02 A E A

ProNet Summa Servo Drive

Rated Output

Voltage

Function

Design Sequence

Sign Spec.	Sign Spec.	Sign Spec.
02: 0.2kW 04: 0.4kW 08: 0.75kW 10: 1kW 15: 1.5kW 20: 2kW 30: 3kW	A: 200VAC	E: EtherCAT H: EtherCAT, STO, Full-closed loop

Ratings

Servo Drive Model: ED3S-	02A	04A	08A	10A	15A	20A	30A
Applicable Servo Motor Model: EM3A-	02A	04A	08A	10A	-	-	-
Applicable Servo Motor Model: EMG-	-	-	-	10A	15A	20A	30A
Continuous Output Current [Arms]	1.5	2.9	5.1	6.9	8.2	11.3	18.0
Max. Output Current [Arms]	5.8	11.5	19.5	21.0	24.6	33.9	54.0
Input Power Capacity [kVA]	0.5	0.9	1.6	2.0	3.0	3.5	4.5

Specification

Items		Specifications	
Input Power Supply	Main Circuit	Single-phase/Three-phase 200~240VAC, +10%~-15% (50/60Hz) 270~324VDC, +10%~-15%	Three-phase 200~240VAC, +10%~-15% (50/60Hz) 270~324VDC, +10%~-15%
	Control Circuit	Single-phase 200~240VAC, +10%~-15% (50/60Hz) 270~324VDC, +10%~-15%	
Control Method		SVPWM Control	
Feedback		Serial Encoders 20bits: 1048576 PPR (incremental) 23bits: 8388608 PPR (absolute)	
Operating Conditions	Ambient/Storage Temperature	Ambient temperature: 0~+55 C Storage temperature: -25~+85 C	
	Ambient/Storage Humidity	5%~95% RH (no condensation)	
	Protection Structure	IP20	
	Altitude	1000m or less	
	Vibration/Impact	Vibration Resistance: 4.9m/s² Impact Resistance: 19.6m/s²	
	Power System	TN system*3	
Installation		Base-mounted	
Performance	Speed Setting		1:5000
	Speed Fluctuation Factors	With Load	0 to 100% load: ±0.01% or less (at rated speed)
		With Voltage	Rated voltage ±10%: 0% (at rated speed)
		With Temperature	25±25°C: ±0.1% or less (at rated speed)
Soft Start-up Setting		0 to 10 s (acceleration and deceleration can be set separately)	
I/O Signals	Encoder Dividing Pulses Output		Phase-A, Phase-B, Phase-C: line driver output Dividing pulses number: determine ratio by setting parameter
	Sequence Input	Channel Number	7 Channels (two channels of them are high-speed Optocoupler input for Touch Probe)
		Functions	Signal allocations and positive & negative logic modifications: servo on (/S-ON); forward run prohibited (/P-OT); reverse run prohibited (/N-OT); forward torque limit (/P-CL); reverse torque limit (/N-CL); gain switch options (/G-SEL); home/reference point switch (/HOME). two high-speed optocoupler channels can be allocated to Touch Probe 1 and Touch Probe 2
	Sequence Output	Channel Number	4 Channels
Functions		Signal allocations and positive/negative logic modifications: positioning completion (/COIN); speed coincidence (/V-CMP); servomotor rotation detection (/TGON); servo ready (/S-RDY); torque limit output (/CLT); brake interlock output (/BK); encoder C pulse (/PGC); over travel signal (/OT). servo excitation (/RD) etc. Of these: servo alarm (ALM); stationary channel; cannot be change	
Dynamic Braking		08A-30A: built-in regenerative resistor; 02A-04A: external regenerative resistor	
Protection Functions		Overcurrent, overvoltage, low voltage, overload, regeneration error, overspeed, etc	
Auxiliary Functions		Alarm trace back, JOG operation, load inertia detection, parameter autotuning, etc	
Optional Functions	Functional safety	STO acc. to IEC 61800-5-2	
	Fully-closed loop control	SIL3 acc. to IEC 61508 and IEC 62061, Cat. 4, PLe acc. to ISO 13849-1 Supporting for A/B/Z, TTL different output	

04

SERVO MOTORS



Part number

EM3A - 02 A F D 2 1 1

Model	Rated Output Power	Supply Voltage	Encoder	Design Sequence	Shaft End	Option Parts	Connector Types
	Sign. Spec.	Sign. Spec.	Sign. Spec.	Sign. Spec.	Sign. Spec.	Sign. Spec.	Sign. Spec.
	A5: 0.05kW 01: 0.1kW 02: 0.2kW 04: 0.4kW 08: 0.75kW 10: 1.0kW	A: 200VAC	F: 20-bit Incremental Encoder L: 23-bit Absolute Encoder	A,B,D, Design M,H Sequence	1: Straight Without Key 2: Straight With Key,screw Thread (Standard)	1: None 2: With Oil Seal 3: With Brake (DC24V) 4: With Oil Seal, With Brake (DC24V)	1: Lead Wire Without Waterproof

EMG - 10 A F A 2 1

Model	Rated Output Power	Supply Voltage	Encoder	Design Sequence	Shaft End	Option Parts
	Sign. Spec.	Sign. Spec.	Sign. Spec.	Sign. Spec.	Sign. Spec.	Sign. Spec.
	10: 1.0kW 15: 1.5kW 20: 2.0kW 30: 3.0kW	A: 200VAC	F: 20-bit Incremental Encoder L: 23-bit Absolute Encoder	A,B,D, Design M,H Sequence	1: Straight Without Key 2: Straight With Key,screw Thread (Standard)	1: None 2: With Oil Seal 3: With Brake (DC24V) 4: With Oil Seal, With Brake (DC24V)



EM3A Servo Motor Specifications

Voltage		200VAC			
Servo Motor model		EM3A-			
		02AFA□□□ 02ALA□□□	04AFA□□□ 04ALA□□□	08AFA□□□ 08ALA□□□	10AFA□□□ 10ALA□□□
Rated Output	kW	0.2	0.4	0.75	1
Rated Torque	N·m	0.63	1.27	2.39	3.18
Instantaneous Peak Torque	N·m	2.21	4.45	8.37	11.13
Rated Current	Arms	1.5	2.9	5.1	6.9
Instantaneous Max current	Arms	5.8	11.5	19.5	21.0
Rated Speed	r/min	3000			
Max. Speed	r/min	6000			
Rotor Moment of Inertia	×10 ⁻⁴ kg·m ²	0.147 (0.179)	0.244 (0.276)	0.909 (1.07)	1.14 (1.30)
Brake Rated Voltage		DC24V±10%			
Brake Rated Power	W	7.4		9.6	
Brake Rated Torque	N·m	1.5		3.2	
Encoder		20-bit Incremental Encoder 1048576 P/R; 23-bit Absolute Encoder 8388608P/R			
Insulation Class		F			
Ambient Temperature		0 ~ +40°C(No freezing)			
Ambient Humidity		20%~80% RH (No condensing)			
Vibration		Vibration: Dynamic 49m/s ² (5G) ; Static 24.5m/s ² ; Shock: 98m/s ² (10G)			
Enclosure		Totally Enclosed,Self-cooled,IP65(Except for shaft opening,when not equipped with oil seal;Except for connector,when not equipped with waterproof plug)			

Note:The data inside parenthesis represents the values with brake.

EMG Servo Motor Specifications

Voltage		200VAC			
Servo Motor model		EMG-			
		10AFD□□ 10ALB□□	15AFD□□ 15ALB□□	20AFD□□ 20ALB□□	30AFD□□ 30ALA□□
Rated Output	kW	1.0	1.5	2.0	3.0
Rated Torque	N·m	4.78	7.16	9.55	14.3
Instantaneous Peak Torque	N·m	14.3	21.5	28.7	40
Rated Current	Arms	5.8	8.2	11.3	18.0
Instantaneous Max current	Arms	17.4	24.6	33.9	54.0
Rated Speed	r/min	2000			
Max. Speed	r/min	3000			
Rotor Moment of Inertia	×10 ⁻⁴ kg·m ²	13.2 (14.3)	18.4 (19.5)	23.5 (24.6)	41.3 (44.5)
Weight	kg	7 (8.5)	8.9 (10.4)	10.8 (12.3)	16.63 (20.23)
Brake Rated Voltage		DC24V±10%			
Brake Rated Power	W	19.5		35	
Brake Rated Torque	N·m	12		40	
Encoder		20-bit Incremental Encoder 1048576 P/R; 23-bit Absolute Encoder 8388608P/R			
Insulation Class		F			
Ambient Temperature		0 ~ +40°C(No freezing)			
Ambient Humidity		20%~80% RH (No condensing)			
Vibration		24.5m/s ²			
Enclosure		Completely Closed, Wind-cooling, Self-cooling,IP65(The Model With Oil Seal,excluding Connecting Joint With Cable)			

Note:The data inside parenthesis represents the values with brake.

EM3A Dimensions

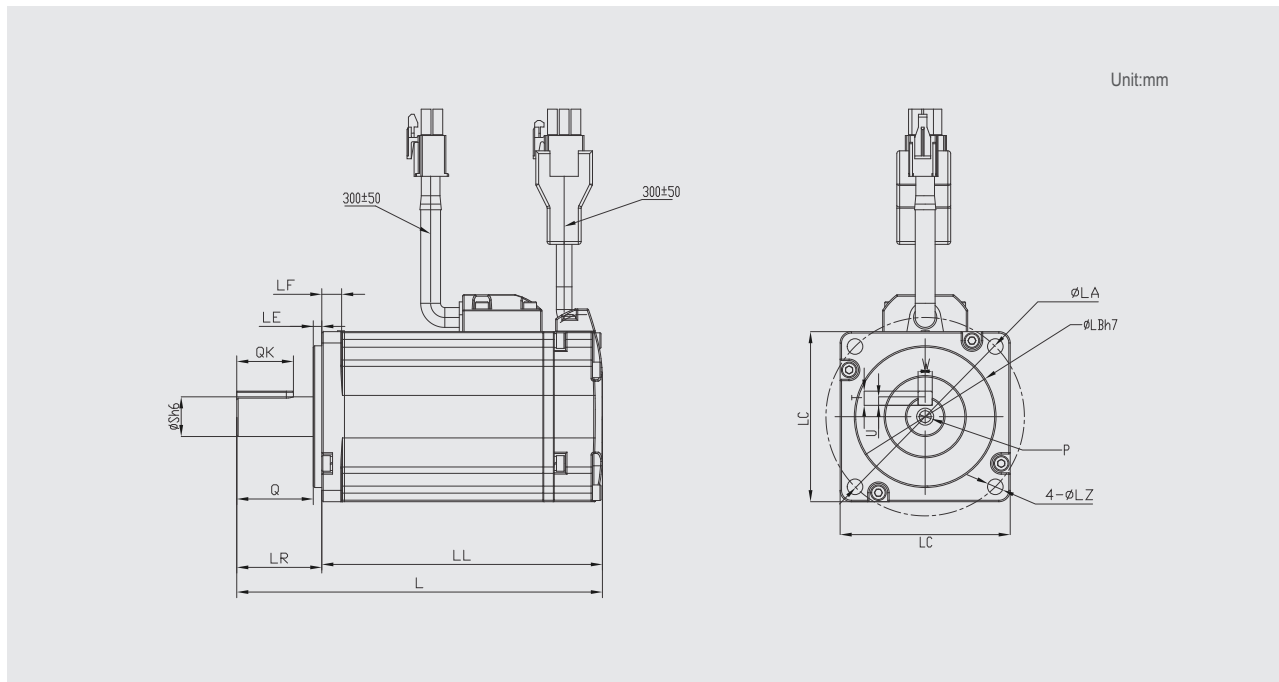

EM3A-	L ①	LL ②	Flange Side							S	Threaded hole x Depth	Key				
			LR	LE	LF	LC	LA	LB	LZ			QK	W	T	U	Q
02ALA	108 (137)	78 (107)	30	3	7	60	70	50	5.5	14	M5X12	20	5	5	3	27
04ALA	129 (158)	99 (128)	30	3	7	60	70	50	5.5	14	M5X12	20	5	5	3	27
08ALA	141(184)	111(144)	40	3	8	80	90	70	6.6	19	M6X12	25	6	6	3.5	37
10ALA	155(198)	125(158)	40	3	8	80	90	70	6.6	19	M6X12	25	6	6	3.5	37
02AFA	126.5(155.5)	96.5(125.5)	30	3	7	60	70	50	5.5	14	M5X12	20	5	5	3	27
04AFA	147.5(176.5)	117.5(146.5)	30	3	7	60	70	50	5.5	14	M5X12	20	5	5	3	27
08AFA	169.5(202.5)	129.5(162.5)	40	3	8	80	90	70	6.6	19	M6X12	25	6	6	3.5	37
10AFA	183.5(216.5)	143.5(176.5)	40	3	8	80	90	70	6.6	19	M6X12	25	6	6	3.5	37

Note: Numbers inside parentheses represents the values with brake.

EM3A Torque-Speed Features

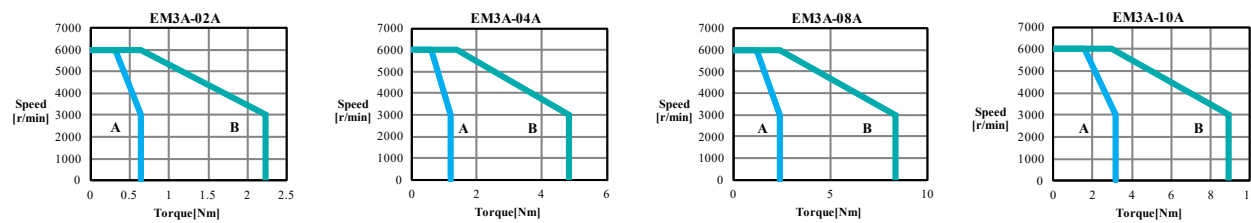

A: Continuous Working Area B: Repeatedly Working Area

EMG Dimensions

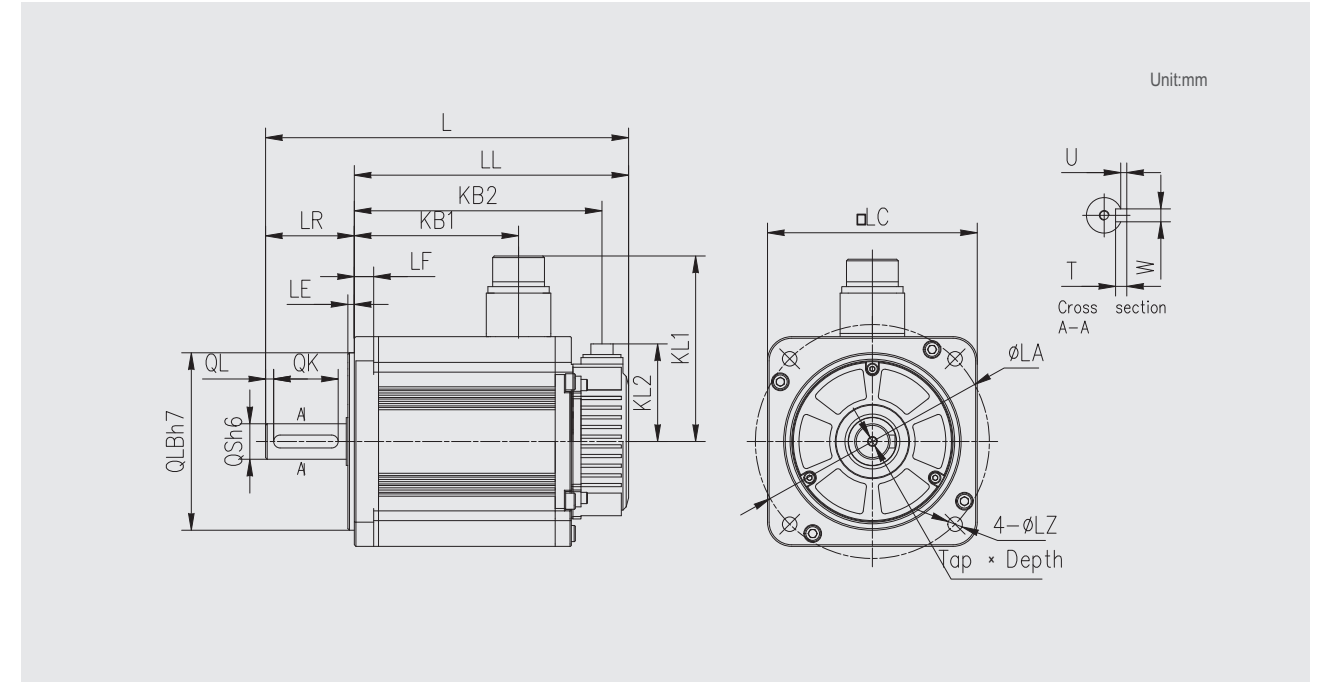

EMG-	L ①	LL ②	KB1 ③	KB2 ④	KL1	KL2	Flange Side							S	Threaded hole x Depth	Key				
							LR	LE	LF	LC	LA	LB	LZ			QK	QL	W	T	U
10I/B/D	203 (245.5)	148 (190.5)	80 (103.2)	131.5 (174)	117	60.5	55	4	12	130	145	110	9	22	M6×20	40	5	8	7	4
15II/B/D	225 (267.5)	170 (212.5)	102 (125.2)	153.5 (196)																
20II/B/D	247 (289.5)	192 (234.5)	124 (147.2)	175.5 (218)																
30II/A/D	307 (378)	228 (299)	143	203 (274)	140	79	79	3.2	18	180	200	114.3	13.5	35	M8×16	55	6	10	8	5

Note: Numbers inside parentheses represents the values with brake.

EMG Torque-Speed Features

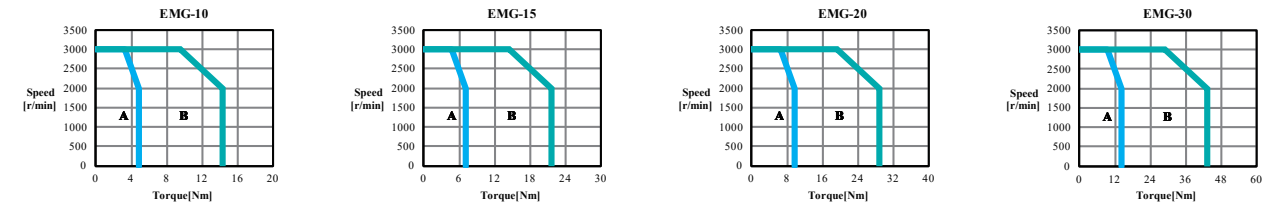

A: Continuous Working Area B: Repeatedly Working Area

05

WIRING

Wiring

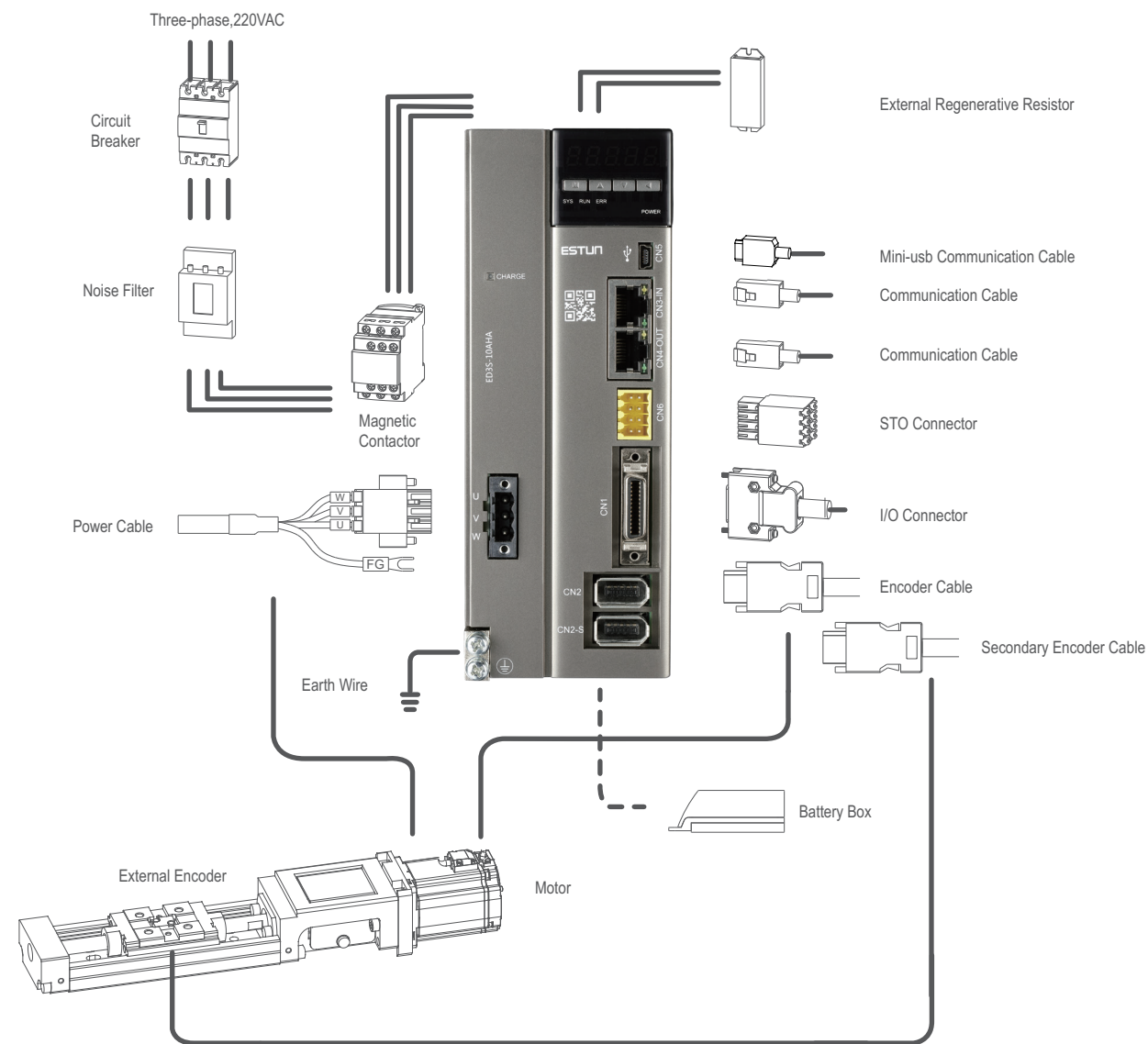

06

ACCESSORIES

Cables

Encoder Cables

EC3S-I1124-XX

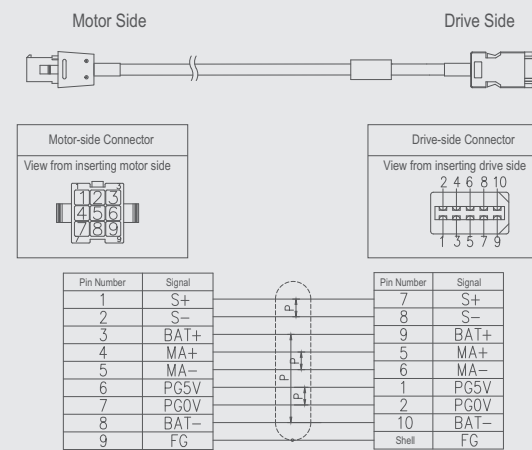

EC3S-I1324-XX

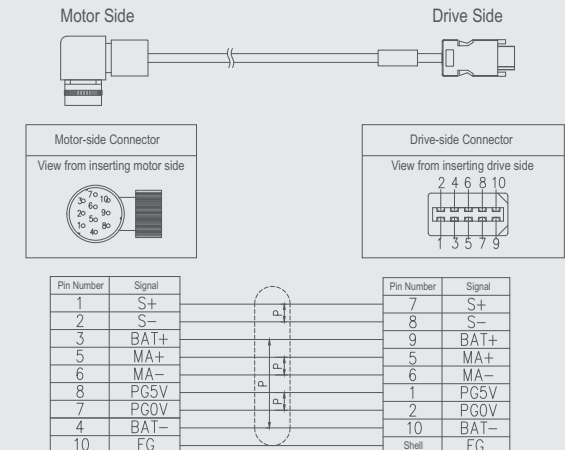

EC3S-I1424-XX

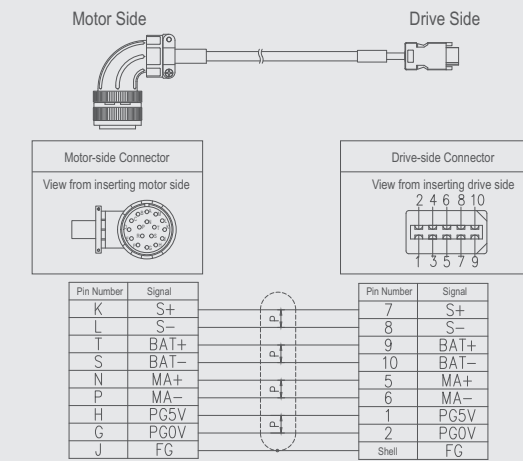

Power Cables

EC3P-B1118-XX

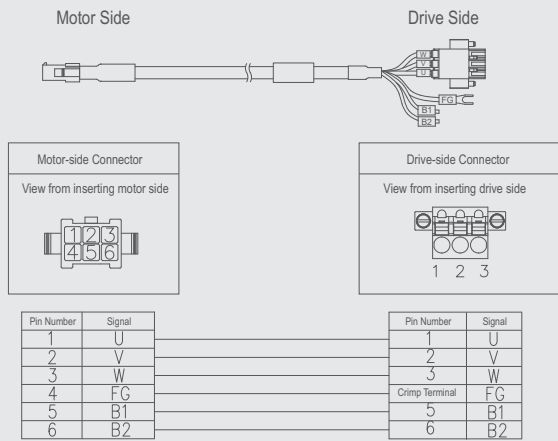

EC3P-N1118-XX

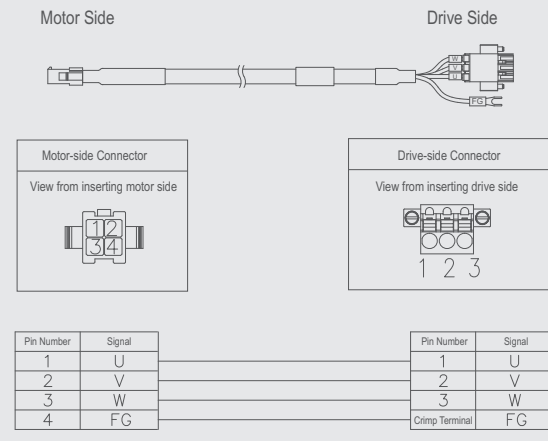

EC3P-N2413-XX

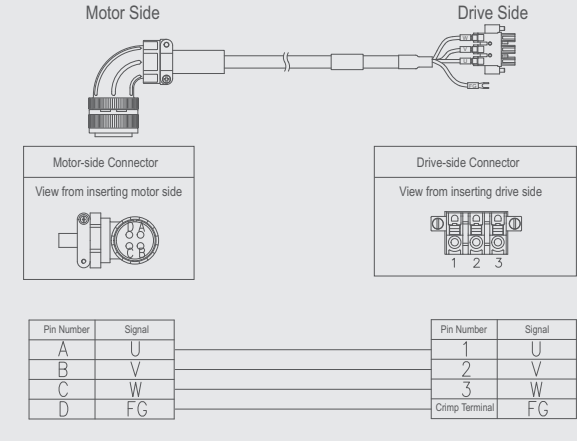

EC3P-B1314-XX

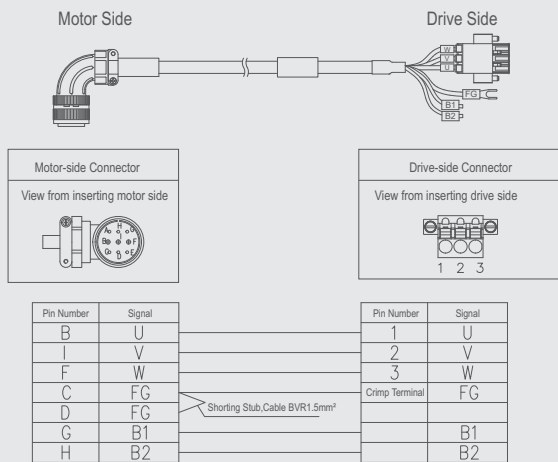

EC3P-N1314-XX

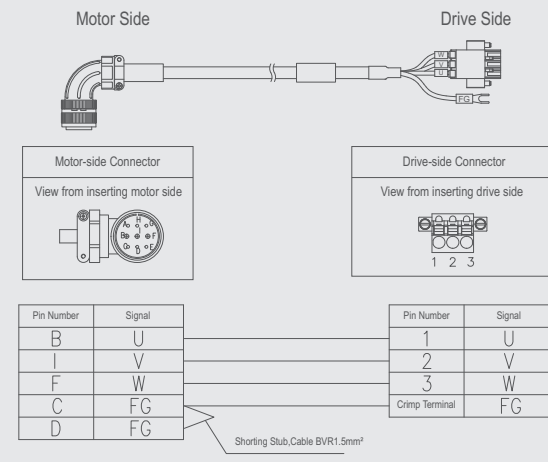

EC3P-B2314-XX

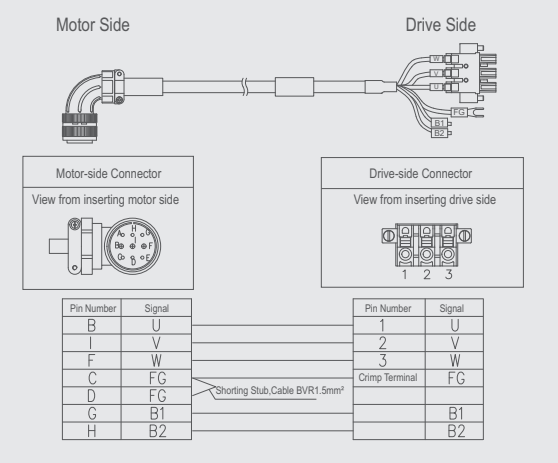

EC3P-N2314-XX

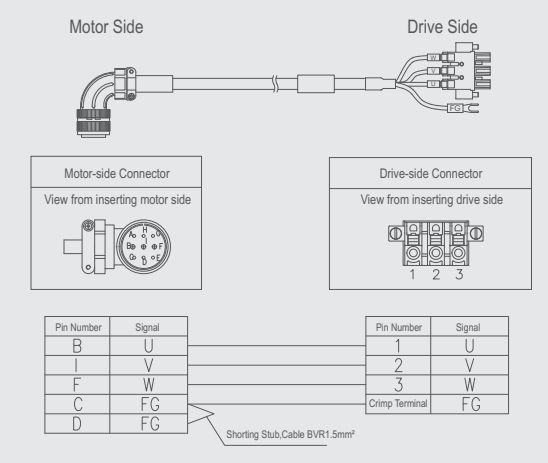

Optional Accessories

Servo Drive	Main Circuit Voltage	Built-in Regenerative Resistor Specifications	Min.Allowable Resistance	Min.Rated Current for Circuit Breaker
ED3S-02A	200-240VAC	—	50	10A
ED3S-04A	200-240VAC	—	50	10A
ED3S-08A	200-240VAC	50 /60W	25	25A
ED3S-10A	200-240VAC	50 /60W	25	25A
ED3S-15A	200-240VAC	40 /80W	10	35A
ED3S-20A	200-240VAC	20 /150W	10	55A
ED3S-30A	200-240VAC	20 /150W	10	70A